

# Corrigent CM-100 Packet Transport

## Data Services in the Packet Transport Solution

### CM-100 Packet Transport

The CM-100 is a carrier-class packet-optimized network element for the transport of data and TDM services. It relies on MPLS and RPR for the creation of a lossless shared media, over which services are efficiently multiplexed with class-of-service guarantees, and provisioned using MPLS control plane technology.

Both data and TDM services are mapped into MPLS consistently with the IETF PWE3 WG methods and procedures. This provides a universally-applicable encapsulation method, enabling full service convergence and efficient packet aggregation and transport of TDM and data services, decoupling services from the physical facility. This in turn allows carriers to provision new data services instantly, without the need to physically allocate timeslots or fiber, recouping lost revenue and reducing churn.

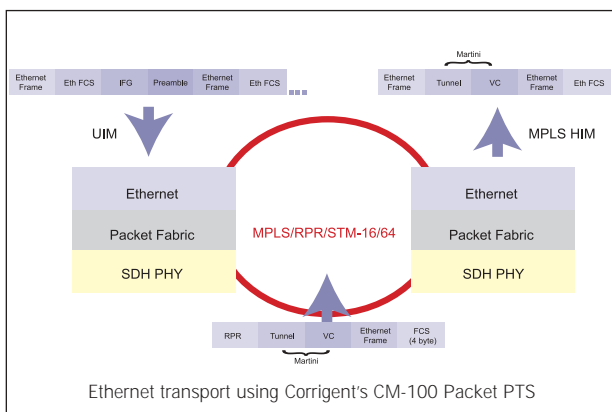

Data services can be provisioned over a number of Ethernet and TDM User Interface Modules (UIM). All services are unidirectionally characterized by user-defined CIR, PIR and CoS parameters.

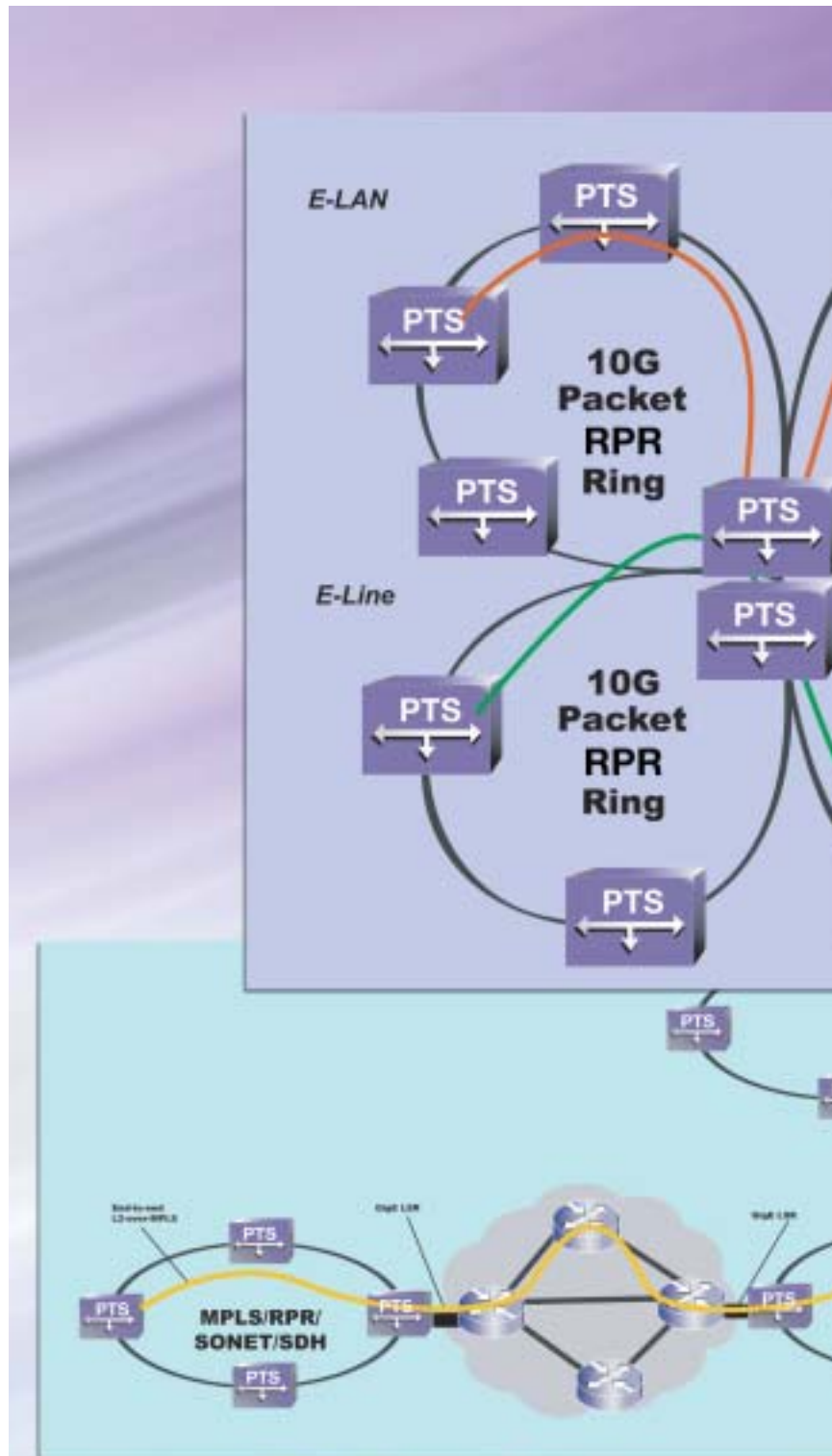

All services can co-exist over the CM-100 Packet Transport network, thus enabling a multi-service transport solution, providing the right infrastructure for enabling the following end-user applications:

- Ethernet Virtual Private Line
- L2 VPN (VPLS)
- Broadband access aggregation
- Triple Play services
- Distribution of multicast traffic such as IPTV
- Backhaul of 3G wireless traffic

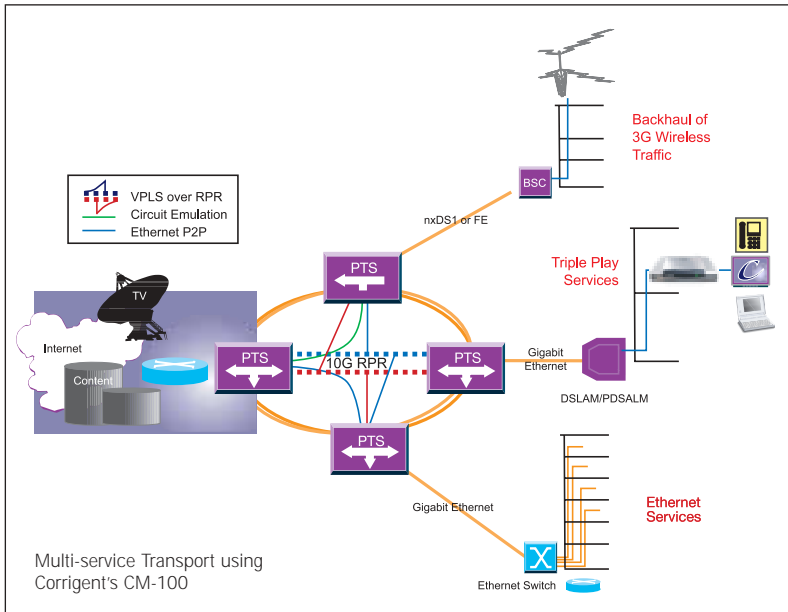

The CM-100 product line consists of two models having the same dimensions and providing the same functionality, only varying in the number user interface modules. The CM-106 supports up to six vertically-aligned UIM/HIM, whereas the CM-110 supports up to ten vertically-aligned UIM/HIM.

Both models support a number of TDM and Data User Interface Modules (UIM), Hub Interface Modules (HIM) and Ring Interface Modules (RIM). The UIM vary from DS1/E1 to DS3 (both channelized and clear channel) PDH rates, from OC-3/STM-1 to OC-48/STM-16 SONET/SDH rates, and from 10/100 FE to 1-10 GE. The GE and OC-48/STM-16 interface cards support two modes of operation: 1) as a tributary (UIM) and 2) as a Hub Interface Module (HIM). The HIM can be used to connect to other CM-100 RPR rings either directly or through an IP/MPLS or SONET/SDH network.

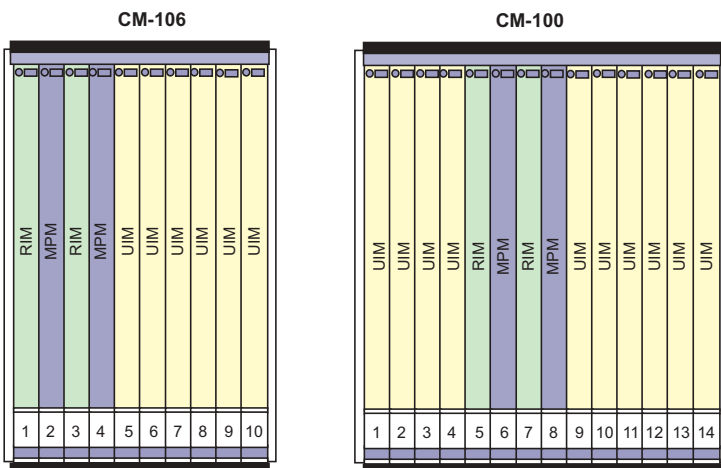

A 3M Company



Quante Netzwerke GmbH  
Ahrensburger Straße 8  
D-30659 Hannover

Tel: +49 (0)511 / 74 01 92-0 ♦ Fax: +49 (0)511 / 74 01 92-100

## Data services supported in Corrigent's CM-100

- E-Line Services (point-to-point Ethernet services)
  - Unclassified (VLAN-based and Port-based)
  - Classified (based on 802.1p, ToS, DSCP)
  - Trunk services
- E-LAN Services (point-to-multipoint Ethernet services)
- PPP/HDLC-based Services
- Idle-byte Suppression (IS) on OC3/STM-1 and OC-12/STM-4 UIM
- FR (port-mode)
- ATM (through Circuit Emulation)
- Fibre Channel over PWE3
- PPP/MLPPP to Ethernet Service Inter-working

TDM	FR	Ethernet	HDLC	FC
IETF MPLS PWE3				
IEEE 802.17 RPR				
SONET/SDH (VCAT)				

Data services mapping

## User Interface Modules (UIM)

- 21 port E1
- 28 port DS1
- 6 port DS3-CH (channelized)
- 9 port DS3 (clear channel)
- 4 port OC-3/STM-1-CH (channelized)
- 8 port OC-3/STM-1
- 8 port OC-3/STM-1-IS (with Idle Suppression)
- 4 port OC-12/STM-4
- 4 port OC-12/STM-4-IS (with Idle Suppression)
- 1 port OC-48/STM-16 (HIM)
- 8 port 1000BaseT/1000BaseX Gigabit Ethernet
- 16 port 10/100BaseT Ethernet
- 1 port 10 Gigabit Ethernet
- 8-port dual Fibre Channel/Gigabit Ethernet

## Ring Interface Modules (RIM)

- 2.5G RPR over SDH/SONET
- 10G RPR over SDH/SONET



www.quante-netzwerke.de